

CONSTRUCTION SITE SAFETY



Calor Gas, Long Mile Road,
Dublin 12.
Tel: (01) 450 5000

www.calorgas.ie

L.P.G. Storage Vessels

Central Storage
Metered Supply
Installations

Distribution
Mains & Services

CALOR

Safety on sites where gas is present

This document details the minimum safety measures that must be employed when working on a site where gas storage vessels and/or gas mains and services are installed. It also includes important information on the properties of LPG and on the procedures to be followed in the case of an emergency.

Contents

	PAGE NO.
CONTACT NUMBERS	2
GENERAL GUIDELINES	4
CONSTRUCTION SITE SAFETY INFORMATION	5
EMERGENCY PROCEDURES	6
INSTALLATION PROCEDURES	7
INSTALLATION GUIDELINES	
GAS MAINS	9
GAS SERVICES	10
METER BOX POSITION	13
METER CABINET/BANK SERVICE	13
METER BOXES	13
METER BOX INTERNALS	15
METER BANK/CABINET POSITIONS	16
INSTALLATION OF APARTMENT METER CABINETS	18
INSTALLATION STANDARDS	20
PRODUCT SAFETY INFORMATION	21

Contact Numbers

Customer Services Department	01 4505000
Calor Gas 24-Hour Emergency Number	01 2694800
Dublin Distribution Terminal.....	01 8555451
Cork Distribution Terminal	021 4502854
Technical Services Department	01 4505000
Installation Department	01 4505000

District Supervisors

If you have any questions please contact your District Supervisor on the number below –

Name:

Tel:

If there are no contact details above please telephone the Installation Department on **01 4505000** (after hours, **01 2694800**), to find the District Supervisor for your area.

General Guidelines

There are certain guidelines which should be adhered to when working in the vicinity of gas vessels and mains. Both the designer and the builder have certain responsibilities to ensure all work is carried out in a safe manner. Details are as follows:

The Designer:

Calor Gas provide drawings for each metered site, LPG vessel, main and service. These are issued at the beginning of the project to the developer/builder and installation contractor. The project designer has responsibilities under Health and Safety regulations to ensure that the existence and location of utility services and LPG Storage Vessels comply with current legislation. Calor maintains a record of its underground storage vessels and distribution pipework on metered estates.

These records are available on request by contacting Calor on Dublin (01) 450 5000.

The Builder:

As stated, it is the responsibility of the project designer to determine the existence and location of all utility services. However the contractor is obliged to check these on site, as utility records may occasionally be incorrect. A record of any such changes to mains and services should be kept by the builder/contractor, to facilitate an 'as built' drawing at the end of the project. To re-cap, a thorough check for services should be undertaken before any excavation takes place on site.

Construction Site – Safety Information

The below procedures should be followed in order to avoid potential loss of life, damage to property, damage to the gas vessels and distribution pipework and delays or disruption to works.

- **DO NOT** ALLOW UNAUTHORISED OR UNTRAINED PERSONNEL TO CARRY OUT WORK ON GAS INSTALLATIONS
- **DO NOT** ATTEMPT TO ALTER, MODIFY, EXTEND OR REPOSITION GAS MAINS OR LPG STORAGE VESSELS
- **DO NOT** CONSTRUCT FOUNDATIONS OR BUILDINGS DIRECTLY OVER GAS MAINS OR SERVICES
- **DO NOT** LEAVE POLYETHYLENE GAS MAINS UNCOVERED OR EXPOSED TO ULTRAVIOLET LIGHT
- **DO NOT** INSTALL OR POSITION ELECTRICAL EQUIPMENT SUCH AS TRANSFORMERS OR DISTRIBUTION UNITS WITHIN 600 MM OF GAS MAINS
- **DO NOT** STORE BUILDING MATERIALS OR FLAMMABLE MATERIALS WITHIN 3 METRES OF LPG STORAGE VESSELS
- **DO NOT** RESTRICT ACCESS TO LPG STORAGE VESSELS, ISOLATING VALVES OR METER INSTALLATIONS
- **DO** ENSURE THAT SITE PERSONNEL KNOW HOW AND WHERE TO TURN OFF THE GAS SUPPLY IN THE EVENT OF AN EMERGENCY
- **DO** RESTRICT UNAUTHORISED ACCESS TO THE LPG STORAGE VESSELS SITE

Note:

Before digging, or operating excavation equipment in the immediate vicinity of LPG storage vessels or gas mains - contact the Calor Technical Department

Emergency Procedures

IN THE EVENT OF DAMAGE TO "GAS MAINS OR TO LPG STORAGE VESSELS". STOP IMMEDIATELY ALL WORK IN THE AREA AND TAKE THE FOLLOWING ACTIONS AND PRECAUTIONARY MEASURES-

- **Shut down** all plant machinery operating in the immediate area of damage
- Turn off the "**Emergency Shut Off Valves**" - located inside the valve chamber on underground vessels and under the hood on above ground vessels (and also at localised line valves if necessary)
- **Do not** operate electrical switches or equipment, or mobile phones near the affected area
- **Do not start** or attempt to move trucks, motor vehicles or other machinery
- **Extinguish** and remove all sources of ignition from the affected area
- **Clear** all personnel from the affected area and restrict unauthorised entry
- **Contact Calor** and in the event of being unable to turn off the gas supply you should also contact the emergency services
- **Take control** of the affected area and keep cordoned off until emergency response crew arrive and take control of the incident
- **Do not** attempt to repair the damage or take remedial action without first getting authorisation and clearance from the gas supplier or the emergency services
- **Do not** recommence work or allow personnel into the affected area until a safety clearance is received from the gas supplier or the emergency services

Installation Procedure

It is normal practice to lay the gas mains and services at the same time as other services, such as water mains, sewage system etc.

In the interests of effective cost management and productivity, a minimum of 5 working days notice to attend on site is normally required

It is expected that a minimum of 100 metres of mains and/or 5 service connections can be made on each site visit

Underground mains and services must be laid in a trench and surrounded by 150mm of sand with a minimum finish cover depth of 600mm for mains and 375mm for services

Gas mains at road crossings must be sleeved or provided with an alternative method of mechanical protection

Polyethylene gas mains and services must always be tested, back filled, covered, and certified before admitting gas

Service lines which cannot be connected to the meter position at the time of installation must either be terminated below ground level or be protected by a GRP sleeve

Before gas is admitted to the end users installation, Calor must receive

- a) a Declaration of Conformance/Safety Certificate (issued by the installer),
- b) a supply agreement (signed by the end user) and c) the connection charge.

Pre-excavation (Existing Site)

There are a number of procedures which must be followed both pre- and during the excavation work. These procedures are detailed below:

- The latest version of the as laid Gas Mains Drawings are available from the Calor Technical Department and must first be consulted prior to excavation. Existing or old valve covers etc. should be observed in order to confirm utility records.
- The depth of the utility from the chambers should be determined.
- Before any work is carried out in the vicinity of existing gas mains, trial holes should be dug by hand to confirm the position and depth of the pipe.

Installation procedure

During Excavation

No unauthorised personnel should undertake work on gas storage vessels, mains or services without prior permission from Calor Installation Department.

Pneumatic or mechanical breakers should only be used when trial holes are being dug to locate services, to break up solid surfacing.

Hand tools should be used for the remainder of the excavation.

Small service pipes are not necessarily marked on record drawings. Therefore, care should be taken with mechanical tools or excavators to avoid snagging during excavation.

A Banksman should accompany mechanical excavators at all times.

Mechanical excavation is not permitted within one metre (1.0m) of the established position of a main or service and 3m of LPG underground vessels.

Hand-held power assisted tools shall not be permitted within half a metre (0.5m) of a gas main or service.

No unauthorised personnel should access or tamper with equipment in the LPG vessel valve chamber.

Where it is necessary to excavate below the level of a gas main, the main shall, during all stages of the operation, be satisfactorily supported.

Piling works should not be carried out within fifteen meters (15m) of a gas main without first consulting Calor

Welding or other hot works, including controlled fires, involving naked flames shall not take place in proximity to an exposed gas main or LPG vessel/valve chamber without written notification to and approval from Calor.

Installation Guidelines

GAS MAINS

Gas mains are normally installed by Calor or their appointed contractor in a pre-excavated trench (provided by the Builder).

All gas main trenches should be excavated to a depth to allow a minimum cover for the gas main of at least 600mm under footpaths and verges and 750mm under roads and carriageways. See figure 1 for details. All gas mains should be 3m from occupied buildings.

Where pipes are laid in raised verges or margins, cover should be measured from the level of the edge of the adjacent carriageway or footpath.

All gas main trenches should be excavated to the width of the outside diameter of the gas pipe plus 300mm.

The gas main should be surrounded by sand and reinstated as soon as practicable after the main is laid, in order to reduce the possibility of external damage on site. Marker tape should be placed over gas main.

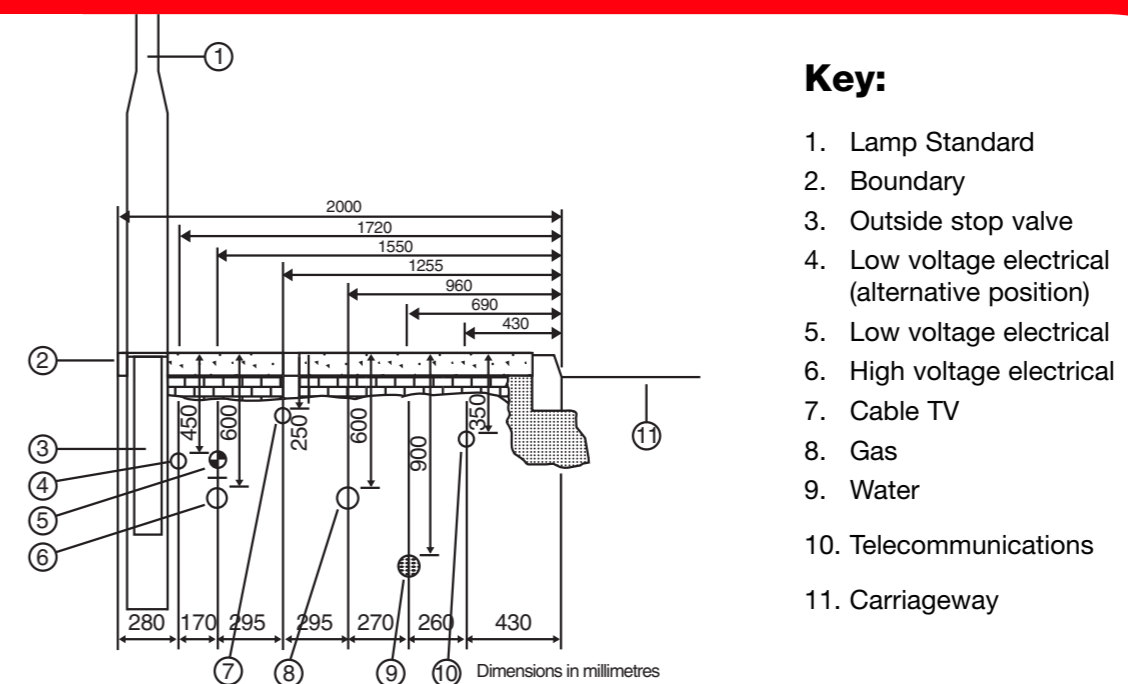

Typical arrangement of mains in a 2m footpath.

Key:

1. Lamp Standard
2. Boundary
3. Outside stop valve
4. Low voltage electrical (alternative position)
5. Low voltage electrical
6. High voltage electrical
7. Cable TV
8. Gas
9. Water
10. Telecommunications
11. Carriageway

Figure 1

Installation Guidelines

Gas Services

Gas services are normally installed by Calor or their appointed contractor in a pre-excavated trench (provided by the Builder)

The gas service should be laid in a straight line and perpendicular to the gas main, as far as practicable, from the main to the meter box position. See Fig. 2 for details.

The gas service trench to each building shall be excavated to a depth to allow a minimum cover of 375mm for each service pipe. (Note: a service to a metre cabinet/bank is an exception to this).

The gas service trench width shall be a minimum of 300mm. (Where ducts are used, see Fig. 2 for details).

The gas service pipe shall be provided with a 150mm-sand surround by the Builder and marker tape must be placed over the gas service.

Normally 32mm size polyethylene service pipe (low pressure) and 25mm size polyethylene service pipe (medium pressure) is used.

Calor approved staff lay and test the gas service in the pre-excavated trench (provided by the Builder) and a top tee connection is made to the main in the path or road, as appropriate.

The gas service shall be sand surrounded and reinstated as soon as practicable after the main is laid, in order to reduce the possibility of external damage on site.

An excess flow limiter should be used on all domestic meter services on central storage sites.

Figure 2

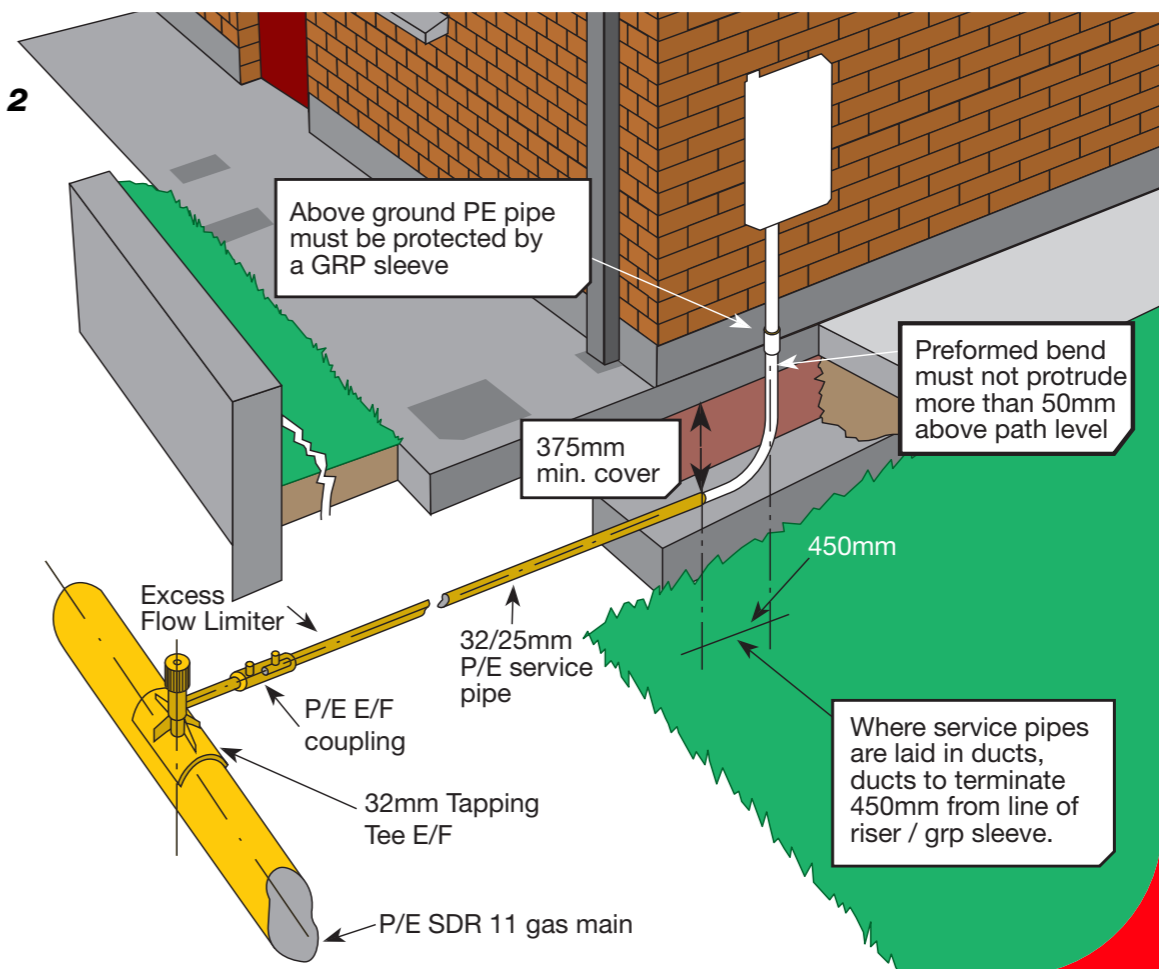

Notes:

- For services a minimum cover of 375mm is required.
- For mains in a carriageway or road a minimum depth of cover of 750mm is required.
- Where it is necessary to cross or run close to any other service, a minimum clearance of 250mm is recommended
- All gas main trenches are to be excavated to the width of the outside diameter of the gas pipe plus 300mm.
- Marker tape should be placed over all gas mains and services and also over ducting intended for gas mains.

Installation Guidelines

Meter Box Positions

The meter box should be positioned so as to allow for the shortest practicable length of service.

Preference should be given to recessing the meter box into the gable, front wall of the house or the boundary wall of the property.

It must be accessible from the front of the house. (See Fig. 3 & 3a).

Figure 3

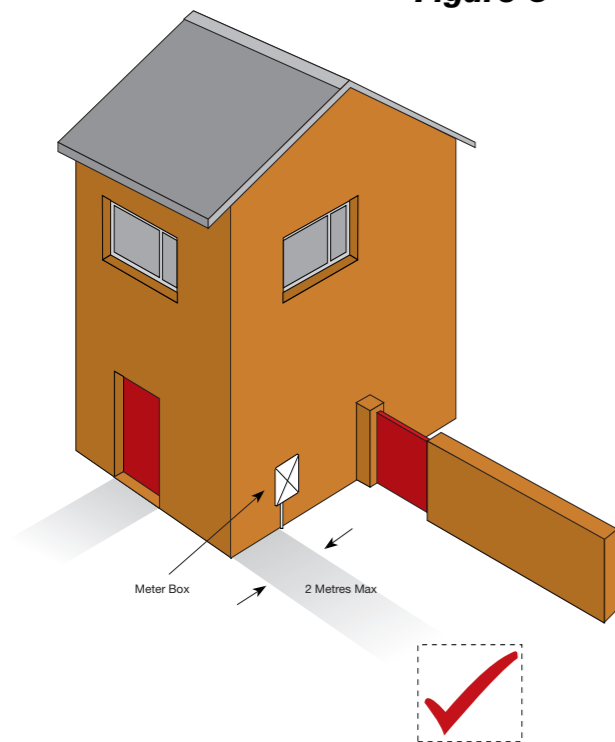

Figure 3a

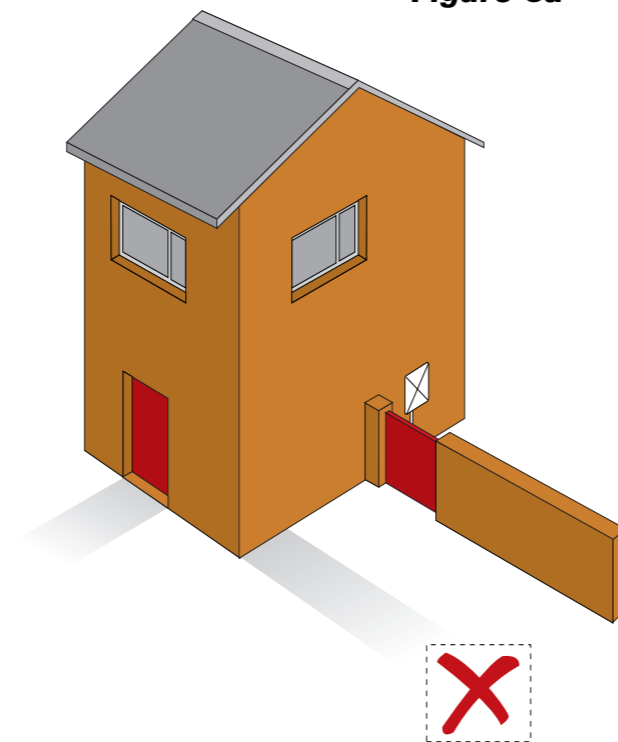
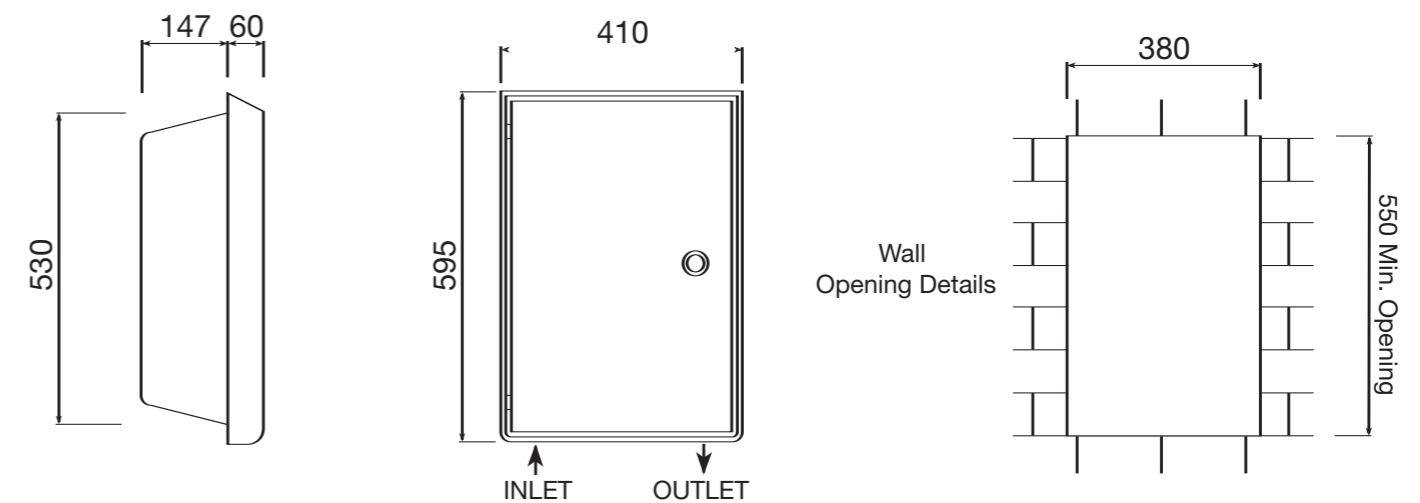

Figure 4



Meter Cabinet / Bank Service

Where a gas service is being laid to a meter cabinet/bank position, the service should be laid so as to allow a minimum cover for the gas service of at least 375mm. Additional protection approved by the gas supplier against damage shall be provided where exceptional circumstances exist.

Meter Boxes

Two types of meter box are available for use by Builders:-

Recessed Wall-Mounted Type: This type of meter box is set into the wall or into a pillar enclosure, See Fig 4 for details.

The recessed meter box and housing must not be punctured or damaged in any way as to allow gas to escape through the box to the structure of the property.

Installation Guidelines

Universal Type Meter box - The universal type meter box can be installed at high or low level.

The wall mounted type is more suitable for installation in existing houses. It can be mounted on the house or bounding walls. See Fig. 5 for details.

The ground mounted type can be semi submerged. Typically in the side entrance or at the front of the house. When installed at ground level the bottom of the box can be set 50mm below ground level (not in concrete path). See Fig. 5a for details.

Figure 5

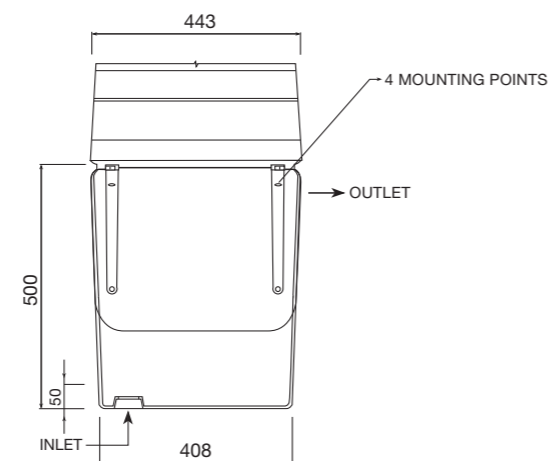
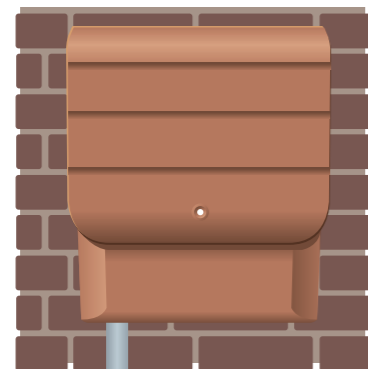
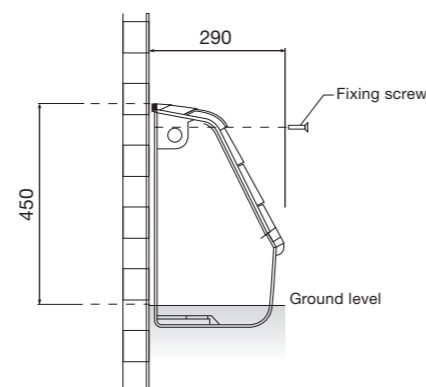

Figure 5a



Meter Box Internals

Canor install a meter box adapter, service valve, regulator and gas meter in the meter box. See Fig. 7 below for the typical layout.

The meter is installed following receipt of the following documents:

- Declaration of Conformance from plumbing contractor.
- Signed contract and direct debit form together with cheque to cover the connection fee sent to Customer Services Department

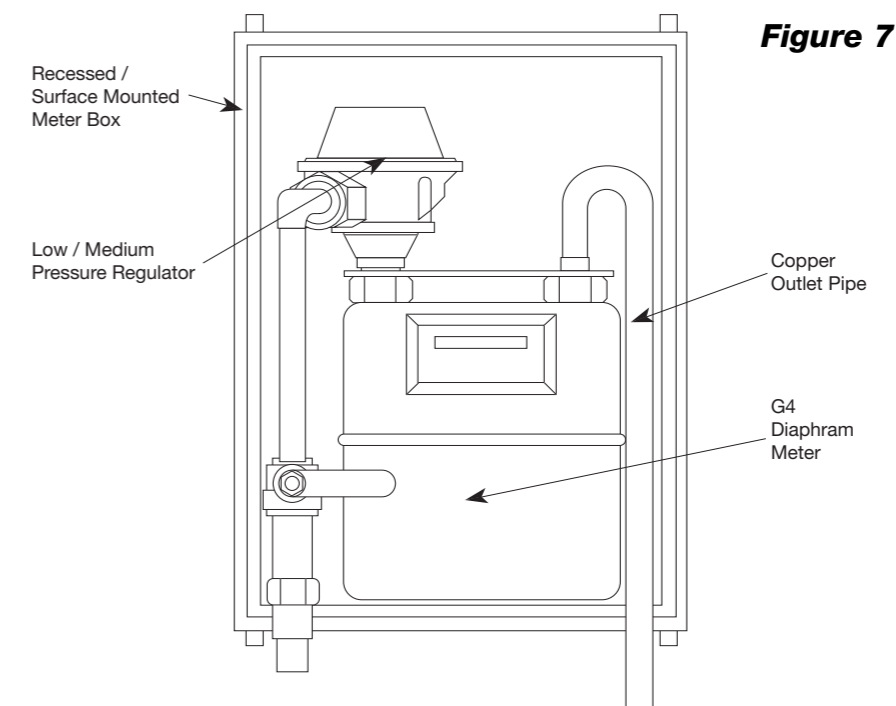

NOTE:

The Builder's Central Heating Installer is responsible for installing and testing the installation pipework connection from the outlet of the meter to the appliances to comply with I.S. 813:2002 for Domestic Gas Installations and I.S. 820:2000 for Non Domestic Gas Installations.

Installation Guidelines

Meter Bank / Cabinet Positions

The preferred location of meter cabinets/banks in apartment blocks are outside the building. Where the cabinet/bank is inside a building, the location should be chosen in order to allow for the shortest practicable length of service. Where up to six meters are to be located in a cabinet (LP or MP meter cabinet), see Fig. 8 for details.

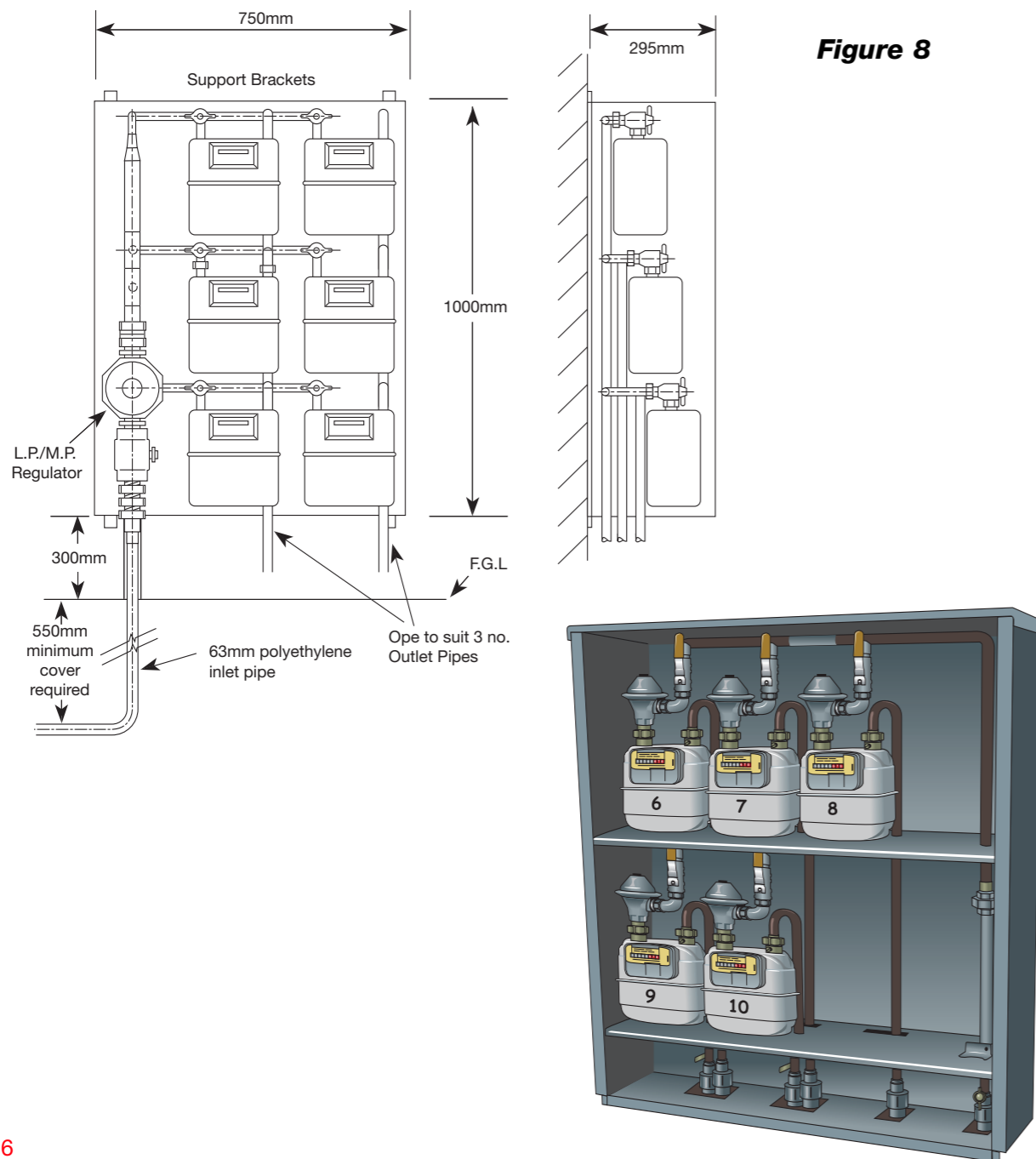
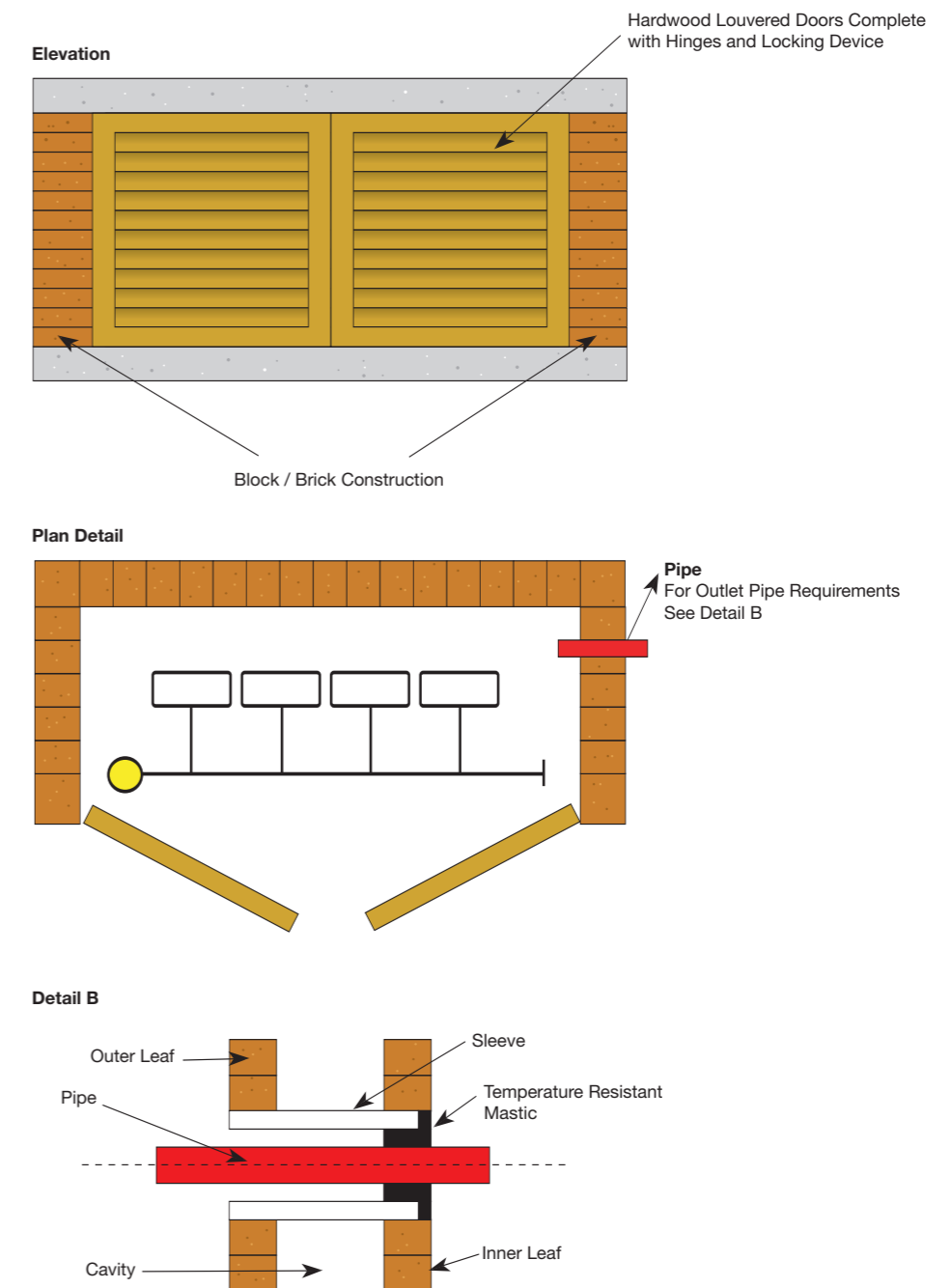

Figure 8

Where more than six meters are required, two options are available:-

- Multiple numbers of LP meter cabinets (6 no. each) are preferably to be located around the complex.
- A large purpose-built and meter bank can be built and the pipework fabricated in a suitable location. See Fig. 9.

Figure 9



Installation Guidelines

Installation of Apartment / Meter Cabinets (GRP)

The pre-assembled meter cabinet is designed to be installed on an outside wall of the building by the Builder using the brackets and bolts supplied. The GRP cabinets are pre-drilled at the back to take the threads of the support bolts. The cabinets are to be installed a minimum of 300mm above FGL in order to allow connection by appointed contractor on site using a service riser (polyethylene to steel).

The meter cabinet supplied as the metering enclosure must not be punctured or damaged in any way as to allow gas to escape through the box to the structure of the property.

Electrical bonding wires must not enter or be attached to any pipes or components within the meter cabinet.

Internal meter cabinets are to have non-locking, self-closing, fire-rated doors. The cabinet must have natural ventilation, high and low, directly to the outside of the building or through fire protected ducts.

Apartment Meter Cabinets / House Internals

Meter Cabinets:

The meter cabinets internals consist of an isolation valve, integral filter, regulator and pre-piped manifold supplying 6 no. domestic meters. The meters are installed when the outlet services have been laid up to the cabinets and when Calor Gas is in receipt of the following documentation:-

- a) Declaration of Conformance Form from Plumbing Contractor
- b) Signed contract and direct debit form together with cheque to cover the connection fee sent to Customer Services Department.

Note:

The Builder's Central Heating Installer is responsible for installing and testing the installation pipework connection from the outlet of the meter to the appliances to comply with I.S. 813:2002 for Domestic Gas Installations and I.S. 820:2000 for Non Domestic Gas Installations.

Meter Rooms

The meter house internals consist of a manifold with individual isolation valves, regulator and domestic meters installed at a later date. The installation of the domestic meters is subject to the same conditions outlined above a) & b).

Note:

Meter banks must be location on the outside wall of apartments in well-ventilated areas provided by the Builder.

Installation Guidelines

Installation Standards

Calor Gas will only connect a gas supply to installations, which conform to the following Irish Standards:

IS 329: 2003 "Code of Practice of Gas Distribution Mains"

IS 265: 2000 "Installation of Gas Service Pipes"

ETCI National rules for electrical installation, Part 1, General Requirements, Section 5.4.6.

Irish Standards IS 813: 2002 for Domestic Gas Installations and I.S. 820:2000 for Non Domestic Gas Installations applies to service downstream of the meter. This Standard is the code of practice of LPG installation requirements downstream of the point of delivery and includes the requirements for meters, appliances and associated pipework in single and multiple occupancy dwelling.

Builder/Developer

Please take note that due consideration should be given to the building regulations requirements Part L in relation to heating controls.

All of the above standards can be obtained from the NSAI (National Standards Authority of Ireland). Tel. No: (01) 8073878.

Product Safety Information

Calor Gas is a highly flammable gas, which is stored in an LPG vessel above or below ground level transported through a network of polyethylene and steel pipes at pressure ranging from 37 mbar to 1bar. Damage to storage vessel or mains`/service pipework can result in the escape of large volumes of gas into the atmosphere in an uncontrolled manner. Even if there is no smell evident you should always report any damage to LPG storage vessels or gas pipe work, regardless of how minor the damage may appear to be at the time, as immediate remedial action and repairs may prevent an accident at a later stage due to corrosion or stress failure.

For further information you should refer to our Product Safety Data Sheet which is available on request from our customers services department.